

RD Ugelli a fessure verticali

Filter nozzles with vertical slots



- Utilizzato quando è necessaria un'ampia superficie filtrante della testa dell'ugello
- Robusto ed economico
- Ampia gamma di fessure
- Di facile pulizia mediante controlavaggio

- Used when a wide filter area of the nozzle head is required
- Strong and inexpensive
- Wide set slots
- Easily cleaned by backwash

Materiale

Material



Modello Model	Fessura Slot width mm	N° Fessure Slots n°	Area mm ²	Colore cupola Head colour
RD	0,20	40 x 2	432	
	0,25	40 x 2	540	
	0,30	36 x 2	582	
	0,35	36 x 2	680	
	0,50	36 x 2	972	
	0,60	36 x 2	1166	

Ugello con certificazione ACS/MOCA prodotto PP Naturale (Bianco) - Ugello in PPFV30% prodotto Naturale (Avorio) - Ugello in PVDF prodotto Naturale (Bianco)
Nozzle with ACS/MOCA certification produced PP Natural (White) - Nozzle in PPFV30% produced Natural (Ivory) - Nozzle in PVDF produced Natural (White)

ORDINE - ORDER

Modello Model	Fessura Slot width	Filetto Thread	ID mm	L1 mm	L2 mm	L3 mm	Materiale Material
RD	0,50	15/16"W	16	50	140	0	PP

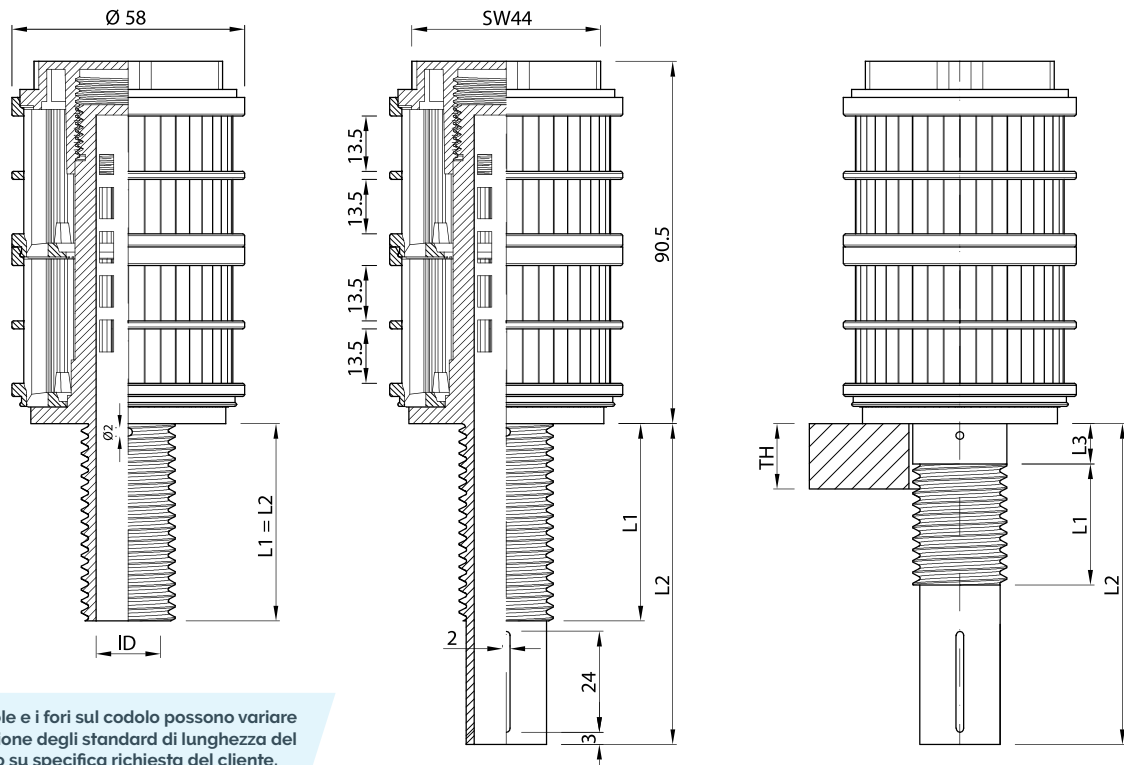

Le asole e i fori sul codolo possono variare in funzione degli standard di lunghezza del codolo o su specifica richiesta del cliente.
The slots and holes on the stem can vary according to the standard length of the stem or on specific customer request.

Filetto Thread	mm	CoL. codolo Stem col.	ID Standard mm	Area codolo Stem area mm ²	L1 - Lunghezza filetto Thread length mm	L2 - Lunghezza codolo Stem length mm	L3 - Scostamento Deviation mm
3/4" G	26,4		16	200	15, 20, 30, 50, 100	... 50, 80, 100, 120, 140, +5 ... 350	0, 5, +5 ...
15/16" W	23,8		16	200	20, 30, 40, 50, 70	... 50, 80, 100, 120, 140, +5 ... 350	0, 5, +5 ...
1" W	25,4		16	200	17, 20, 25, 30, 50	... 50, 80, 100, 120, 140, +5 ... 350	0, 5, +5 ...
M24 x 3,0	24		16	200	20, 30, 40, 50	... 50, 80, 100, 120, 140, +5 ... 350	0, 5, +5 ...
M27 x 3,0	27		16	200	20, 50	... 50, 80, 100, 120, 140, +5 ... 350	0, 5, +5 ...

E' possibile creare ogni configurazione su specifica richiesta del cliente.
It's possible to create any configuration on specific customer need.

NOZZLE RD - ID16

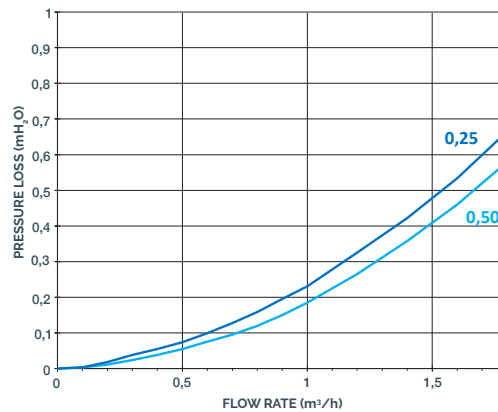

NOTE

Su richiesta è possibile fornire la Curva di Perdita di Carico per tutta la gamma di ugelli ilmap.
The Pressure Loss Curve of the Ilmap Nozzles range can be supplied on demand.